

ESS Solution

SE-F5 & SE-F5 Plus & SE-F5 Pro & SE-F12 & SE-F12 Max & SE-F16 & SE-F16 Max



• SE-F5 & F5 Plus



• SE-F5 Pro



• SE-F12



• SE-F16

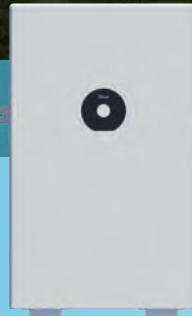

• SE-F12 Max

🔇 IP65



• SE-F16 Max

🔇 IP65

SE-F5 & SE-F5 Plus & SE-F5 Pro & SE-F12 & SE-F12 Max & SE-F16 & SE-F16 Max

Comprehensive Protection

— Advanced BMS with active fuse

Superior Performance

— Support Max. 1C charge & 1.2C discharge (SE-F5 & F5 Plus), GaN MOSFETs: 50% loss reduction, high-temp resistance

Optimized Energy Density

— Integrated PACK: reduced line loss, enhanced energy density

Flexible Expansion

— Max. 32 units in parallel

Easy Maintenance

— Auto-networking, Local monitoring mode for battery, remote monitoring mode for ESS

Reliable Durability

— Operates reliably in -20°C to 55°C, natural cooling

ESS Solution



Model

Main Parameters

	SE-F5	SE-F5 Plus	SE-F5 Pro
Battery Chemistry	LiFePO ₄		
Capacity	100 Ah		
Scalability ^[1]	Max. 32 pcs in parallel		
Nominal Voltage	51.2 V		
Operating Voltage	44.8 V ~ 57.6 V		
Nominal Energy	5.12 kWh		
Charge Current ^[2]	100 A		
		120 A (10 sec)	150 A (120 sec)
Discharge Current ^[2]	120 A		
		150 A (10 sec)	150 A (120 sec)

Other Parameter

Recommend Depth of Discharge	80% DoD	90% DoD	90% DoD
Dimension (W × H × D) (Without hanging board)mm	370 × 548 × 140 mm		404 × 547 × 141 mm
Weight Approximate	41 kg		44 kg
LED Indicator	LED (SOC, working, protecting) & Buzzer		
IP Rating of Enclosure	IP21		
Operating Temperature	Charge: 0~55°C / Discharge: -20~55°C	Charge: -10~55°C / Discharge: -20~55°C	Charge: 0°C~55°C Discharge: -20°C~55°C
Storage Temperature	0°C~35°C		
Relative Humidity	95% (non-condensing)		
Altitude	≤3000m		
Cycle Life	≥6000(25°C±2°C ,70%EOL)		
Installation	Wall-Mounted, Floor-Mounted, Stack-Mounted		
Communication	CAN2.0, RS485, Bluetooth+APP		CAN2.0, RS485, Optional module, (WiFi+Bluetooth+APP)
Warranty Period ^[3]	5 years	10 years	
Energy Throughput ^[3]	8 MWh	16 MWh	
Certification	UN38.3, MSDS, CE, CB		UN38.3, MSDS, CE, CB, VDE2510-50, CEC

[1] Max. 64 pcs can parallel with CAN-Bridge.

[2] Operating current is affected by temperature and SOC.

[3] Conditions apply, refer to Deye Warranty Letter.

ESS Solution



Model		SE-F12	SE-F12 Max	SE-F16	SE-F16 Max
Main Parameters					
Battery Chemistry		LiFePO ₄			
Capacity		230 Ah		314 Ah	
Scalability ^[1]		Max. 32 pcs in parallel			
Nominal Voltage		51.2 V			
Operating Voltage		44.8 V ~ 57.6 V			
Nominal Energy		11.8 kWh		16 kWh	
Charge Current ^[2]	Max. Continuous	230 A		160 A	
	Peak	280 A (10 sec)			
Discharge Current ^[2]	Max. Continuous	230 A			
	Peak	280 A (10 sec)			
Other Parameter					
Recommend Depth of Discharge		90% DoD			
Dimension (W × H × D) (Without hanging board)mm		400 × 559 × 233	464x767x244.5	400 × 708 × 233	464 x 914 x 244.5
Weight Approximate		84 kg	≈93 kg	109 kg	≈118 kg
LED Indicator		LED (SOC, working, protecting) & Buzzer	LCD(SOC, Alarm), LED (Working)	LED (SOC, working, protecting) & Buzzer	LCD(SOC, Alarm), LED (Working)
IP Rating of Enclosure		IP21	IP65	IP21	IP65
Operating Temperature		Charge: 0~55°C (-20~55°C, 12 Max/16 Max with Optional heating)			Discharge: -20~55°C
Storage Temperature		0°C~35°C			
Relative Humidity		95% (non-condensing)			
Altitude		≤3000m			
Cycle Life		≥6000(25°C±2°C ,70%EOL)			
Installation		Wall-Mounted, Floor-Mounted, Stack-Mounted			
Communication		CAN2.0, RS485, Bluetooth+APP	CAN2.0, RS485, Bluetooth+APP	CAN2.0, RS485, Bluetooth+APP	CAN2.0, RS485, Bluetooth+APP
Warranty Period ^[3]		10 years	10 years	10 years	10 years
Energy Throughput ^[3]		37 MWh	37 MWh	50 MWh	50 MWh
Certification		UN38.3, CE, CB	UN38.3, CE, CB	UN38.3, CE, CB	UN38.3, CE, CB, UL1973, UL9540A, UL9540-DC, FCC

[1] Max. 64 pcs can parallel with CAN-Bridge.

[2] Operating current is affected by temperature and SOC.

[3] Conditions apply, refer to Deye Warranty Letter.

Product comparison

Model	Nominal Energy	Charge / Discharge Rate	DoD	Warranty	Size
SE-F5	5.12kWh, 51.2V, 100Ah	1C/1.2C	80%	5years	370 x 548 x 140 mm
SE-F5 Plus	5.12kWh, 51.2V, 100Ah	1C/1.2C	90%	10years	370 x 548 x 140 mm
SE-F5 Pro	5.12kWh, 51.2V, 100Ah	1C/1C	90%	10years	404 x 547 x 141 mm
SE-F12	11.8kWh, 51.2V, 230Ah	1C/1C	90%	10years	400 x 583 x 233 mm
SE-F12 Max	11.8kWh, 51.2V, 230Ah	1C/1C	90%	10years	464 x 778 x 267 mm
SE-F16	16kWh, 51.2V, 314Ah	0.5C/0.7C	90%	10years	400 x 708 x 233 mm
SE-F16 Max	16kWh, 51.2V, 314Ah	0.5C/0.7C	90%	10years	464 x 925 x 267 mm

Mounting example

Stacked

Supports 6 layers in parallel (4 layers for SE-F16/F12 Max/F16 Max), allows multiple clusters in parallel



SE-F5 & SE-F5 Plus

SE-F5 Pro

SE-F12

SE-F16

Wall mounted

All support wall mounted installation, and support for multiple packs in parallel



SE-F5 & SE-F5 Plus

SE-F5 Pro

SE-F12

SE-F16

SE-F12 Max

SE-F16 Max

Optional wheels available for SE-F12 & SE-F12 Max & SE-F16 & SE-F16 Max



SE-F12

SE-F16

SE-F12 Max

SE-F16 Max

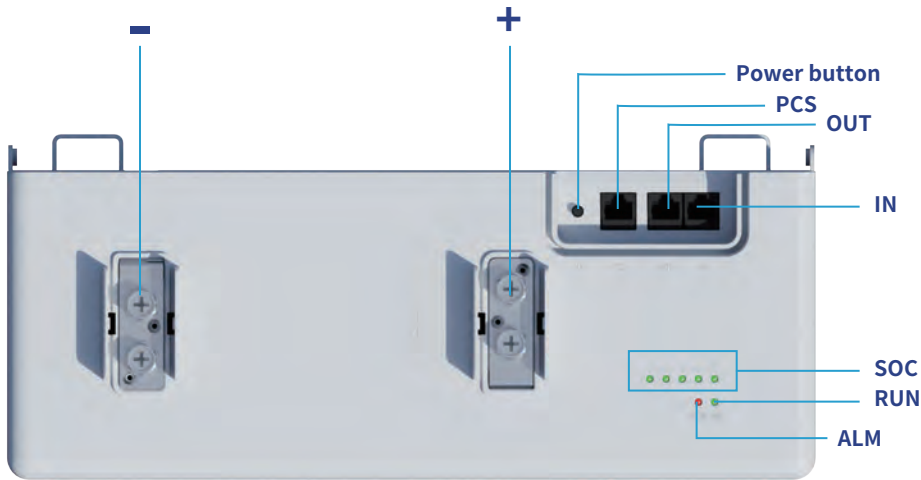

- ⊙ -: Battery negative terminal connection position.
- ⊙ +: Battery positive terminal connection position.
- ⊙ SOC: These 5 LEDs are used to display the pack SOC and charge or discharge state.
- ⊙ RUN light: green LED lighting to show the battery running status.
- ⊙ ALM light: red LED lighting to show the battery has been alarmed .
- ⊙ Power button: Power on or off the control battery.
- ⊙ PCS: Inverter communication terminal:(RJ45port) follow the CAN protocol (baud rate:500kbps),and RS485(baud rate:9600bps),used to output battery information to the inverter.
- ⊙ OUT: parallel Communication Terminal:(RJ45port) Connect "IN"Terminal of Next battery,for Communication between multiple parallel batteries.
- ⊙ IN: parallel Communication Terminal: (RJ45 port) Connect "OUT" Terminal of Previous battery,for Communication between multiple parallel batteries.

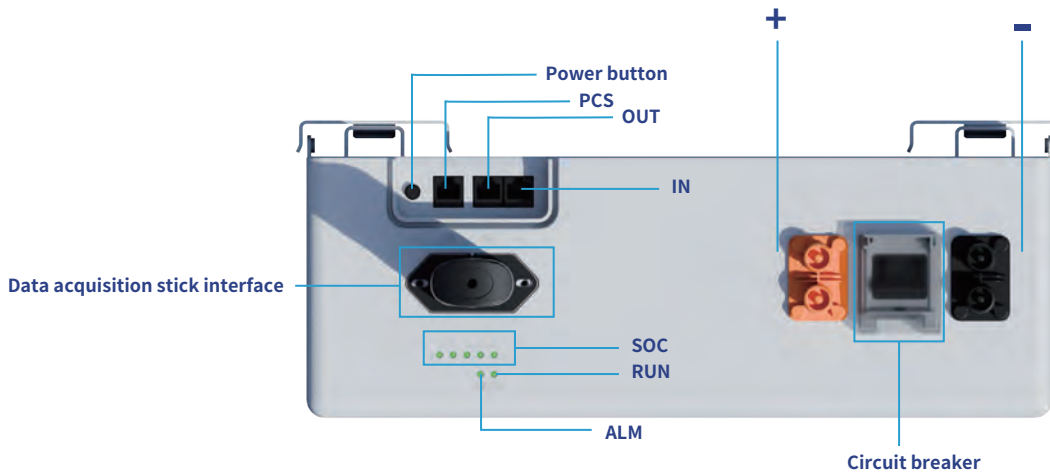

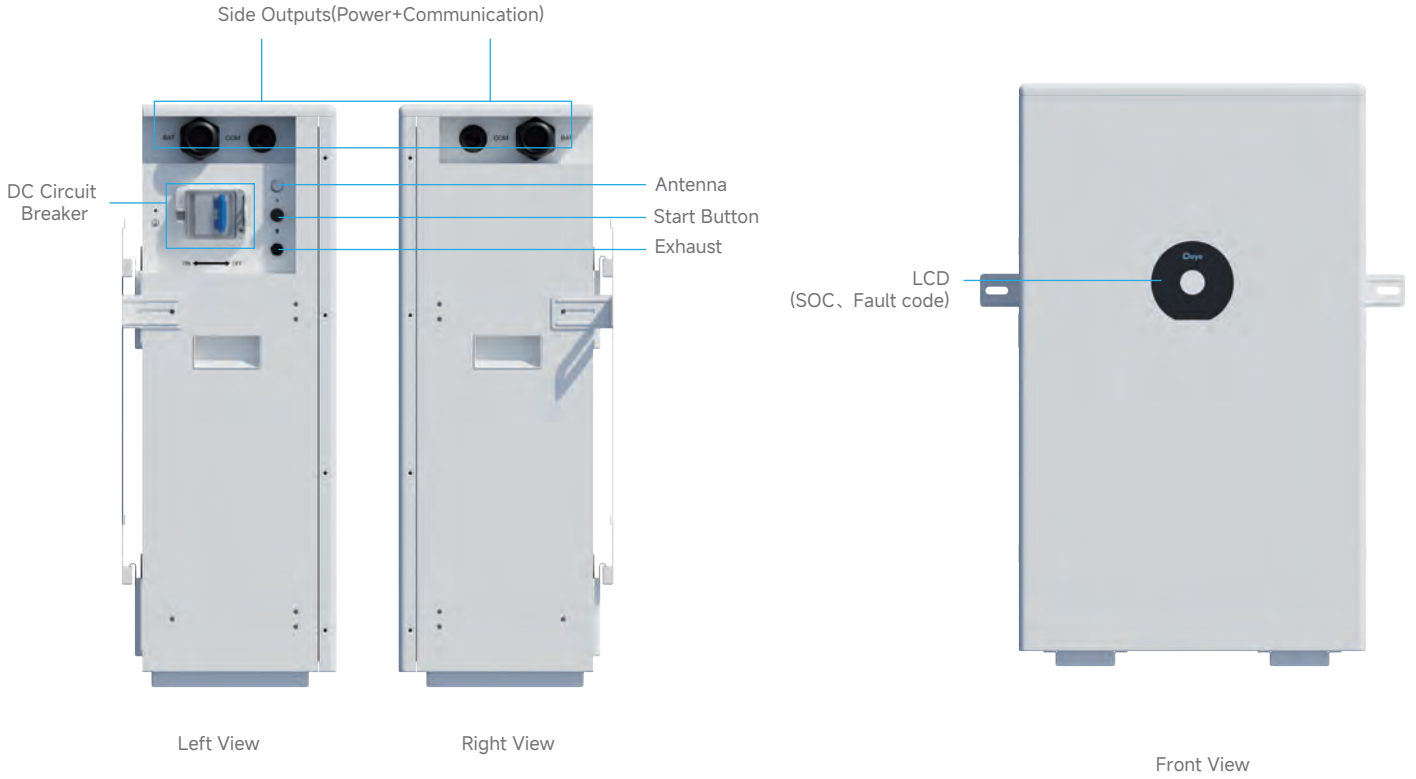

- ⊙ -: Battery negative terminal connection position(Quickly plug and unplug).
- ⊙ +: Battery positive terminal connection position(Quickly plug and unplug).
- ⊙ SOC: These 5 LEDs are used to display the pack SOC and charge or discharge state.
- ⊙ RUN light: green LED lighting to show the battery running status.
- ⊙ ALM light: red LED lighting to show the battery has been alarmed .
- ⊙ Power button: Power on or off the control battery.
- ⊙ PCS: Inverter communication terminal:(RJ45port) follow the CAN protocol (baud rate:500kbps),and RS485(baud rate:9600bps),used to output battery information to the inverter.
- ⊙ OUT: parallel Communication Terminal:(RJ45port) Connect "IN"Terminal of Next battery,for Communication between multiple parallel batteries.
- ⊙ IN: parallel Communication Terminal: (RJ45 port) Connect "OUT" Terminal of Previous battery,for Communication between multiple parallel batteries.
- ⊙ Circuit breaker: Used to manually control the connection between the battery rack and external devices.
- ⊙ Data acquisition stick interface: The location to connect with your Data Logger that is used for data acquisition via WIFI or Bluetooth.

Without Junction Box(SE-F12 Max & F16 Max)(For EU、AS、AF、LATAM)



SE-F Series Model Selection and Appearance Reference



Model	Config Version	Reference
SE-F5/F5 Plus/F5 Pro/F12/F16	L	
SE-F5/F5 Plus/F5 Pro/F12/F16	E	
SE-F5/F5 Plus/F5 Pro/F12/F16/F12 Max/F16 Max	C	

Deye Smart Energy Management System(Optional)

The Deye Smart Energy Management System enables seamless control with smart CT, smart plug, smart switch and solar EV charging, ensuring efficiency and full compatibility with Deye inverters.

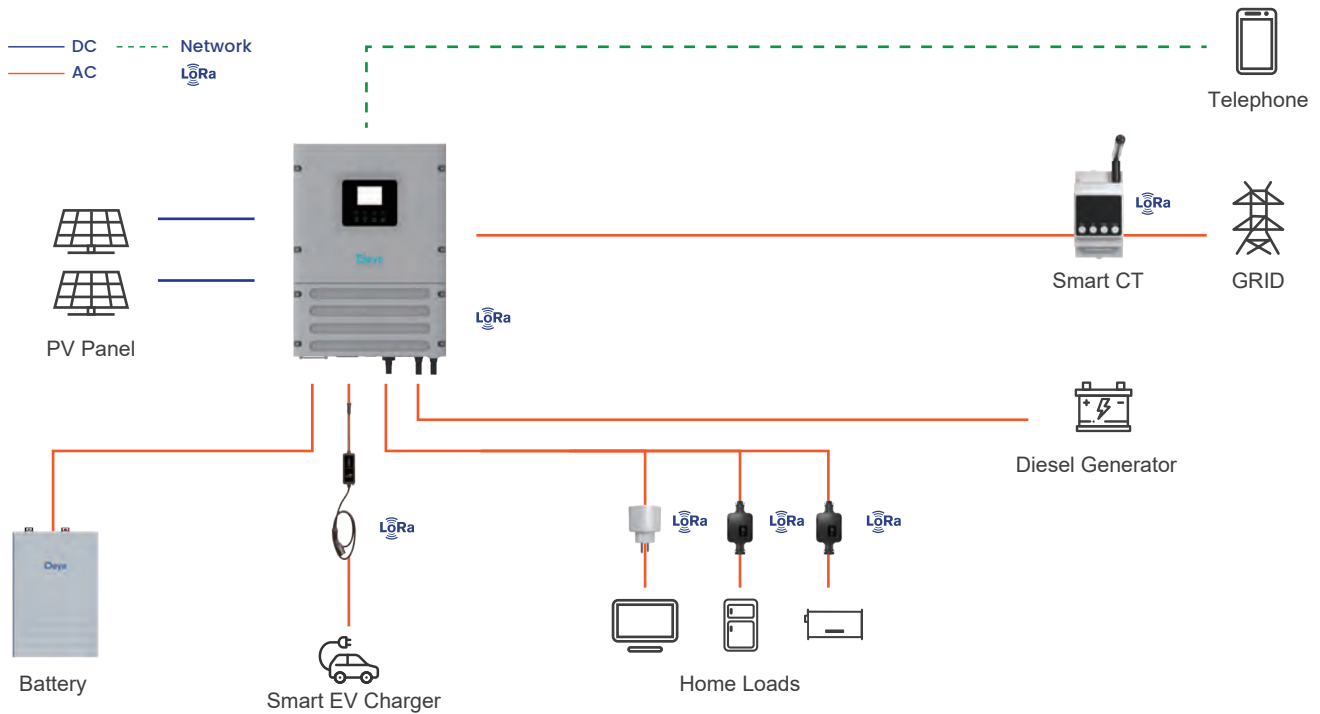

Key Features

- Wireless Zero Export Control**
Enables seamless zero export without the need for complex wiring, simplifying installation.
- Intelligent Load Control**
Automatically manages loads based on time schedules and battery SOC, optimizing energy distribution.
- Solar-Powered EV Charging**
Supports 100% solar charging with dynamic power adjustment for enhanced efficiency and sustainability.
- Full Compatibility**
All Deye hybrid inverters can be upgraded to support this system, ensuring seamless integration with existing setups.
- Precise Off-Grid Load Management**
Ensures that only non-essential loads are disconnected during off-grid operation, maintaining power supply for critical applications.



Deye APP

Bluetooth APP Monitoring

Low Power (Bluetooth LE)

Automated upgrade



Local monitoring mode for battery



Quick Pairing

No Internet Needed

Portable Control



Remote monitoring mode for ESS(Inverter&Battery)



Real-time Equipment Monitoring

Intelligent Charging/Discharging Strategies

AI Data Analytics

Customized Maintenance

Smarten Up Your Home Energy



Download Deye APP to join us!

Embrace a seamless, effortless energy experience that's both ecofriendly and budget-friendly with our intelligent assistant





POWERING YOUR LIFE



www.deyeess.com / www.deyeinverter.com



Deye ESS / Deye New Energy